



## 6900 Series

- 6900C – 19.6 GPM Pump/ Cast Iron
- 6900CR – 19.6 GPM Pump/ Cast Iron Reverse Rotation/Clockwise
- 6601C – 19.6 GPM Pump/ Cast Iron Rear Ports (Not Field Serviceable)
- DKP-6900C – 19.6 GPM Pump/ Cast Iron
- #90200 Coupler and Torque Arm Kit
- 6900DSS – 19.6 GPM Pump/ Diamond Stainless Steel
- 6900DSSR – 19.6 GPM Pump/ Diamond Stainless Steel Reverse Rotation / Clockwise
- DPK-6900DSS - 19.6 GPM Pump/ Diamond Stainless Steel
- #90200 Coupler and Torque Arm Kit

### Pump:

- Type: 6-roller design
- Max Pressure: 300 PSI
- Max Recommended Temperature: 140°F
- Port Size: 3/4" FNPT
- 6900: side ports
- 6901: rear ports – Not field serviceable
- Mounting: Base Mounted: 5/16" – 18UNC-2B (2 holes)
- PTO: Use Torque Bar and Chain Weight: 9 lbs

### Materials of Construction:

- Pump Housing: Cast Iron or Stainless Steel
- Rollers: 1/2" Ultra Rollers
- Shaft Seals: Viton cartridge type lip seals
- Shaft & Rotor: C Extra-fine finish 404 SST
- DSS: Extra-fine finish 416 SST
- Bearings: Permanently-lubricated, heavy-duty sealed bearings

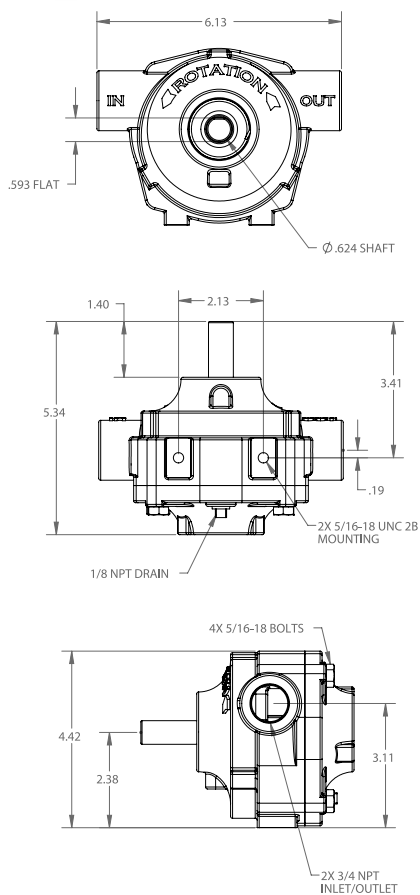

## 6900 Series Performance

PSI	540 RPM	1000 RPM	1200 RPM
0	10.5	19.6	22.8
20	9.7	19.0	22.0
40	8.6	18.4	21.3
60	6.9	16.3	19.7
80	4.8	13.9	17.9
100	3.0	11.5	15.8